



Intel® RealSense™ Product Family D400 Series Calibration Tools and API

Programmer Guide

December 2024

Version 2.14.2.0



INTEL CONFIDENTIAL

Copyright (2018 - 2024) Intel Corporation.

This software and the related documents are Intel copyrighted materials, and your use of them is governed by the express license under which they were provided to you ("License"). Unless the License provides otherwise, you may not use, modify, copy, publish, distribute, disclose or transmit this software or the related documents without Intel's prior written permission.



Intel products described herein. You agree to grant Intel a non-exclusive, royalty-free license to any patent claim thereafter drafted which includes subject matter disclosed herein.

No license (express or implied, by estoppel or otherwise) to any intellectual property rights is granted by this document.

Intel technologies' features and benefits depend on system configuration and may require enabled hardware, software or service activation. Performance varies depending on system configuration. No computer system can be absolutely secure. Check with your system manufacturer or retailer or learn more at intel.com.

Intel technologies may require enabled hardware, specific software, or services activation. Check with your system manufacturer or retailer.

The products described may contain design defects or errors known as errata which may cause the product to deviate from published specifications. Current characterized errata are available on request.

Intel disclaims all express and implied warranties, including without limitation, the implied warranties of merchantability, fitness for a particular purpose, and non-infringement, as well as any warranty arising from course of performance, course of dealing, or usage in trade.

All information provided here is subject to change without notice. Contact your Intel representative to obtain the latest Intel product specifications and roadmaps.

Copies of documents which have an order number and are referenced in this document may be obtained by calling 1-800-548-4725 or visit www.intel.com/design/literature.htm.

Intel and the Intel logo Xeon, Core trademarks of Intel Corporation in the U.S. and/or other countries.

*Other names and brands may be claimed as the property of others.

© 2024 Intel Corporation. All rights reserved.

Contents

1	Scope	8
2	Software Architecture and Calibration Flow	9
	2.1 Software Stack	9
	2.2 Calibration API	10
	2.3 API Package Location	10
	2.4 API Package Structure	10
	2.5 Compiling Examples.....	11
	2.6 Calibration Parameters	13
	2.7 Dynamic Calibration with Intel Algorithms	14
	2.7.1 Target-less	14
	2.7.2 Target-based	16
	2.7.3 Hybrid	19
	2.7.4 Image Formats Used in Dynamic Calibration	20
	2.8 Depth/RGB Custom Calibration with User Algorithms	20
	2.9 Fisheye Custom Calibration with User Algorithms	21
3	Calibrating Depth/RGB with Intel Algorithm through Dynamic Calibration API	23
	3.1 Targeted Calibration	23
	3.2 Target-less Calibration.....	24
	3.3 Hybrid Calibration	25
	3.4 Sample Dynamic Calibrator Application	27
4	Depth/RGB Custom Calibration R/W	28
	4.1 Interfaces	28
	4.1.1 Initialize	28
	4.1.2 WriteCustomCalibrationParameters	28
	4.1.3 ReadCalibrationParameters	29
	4.1.4 ResetDeviceCalibration	30
	4.1.5 ReadCalibrationRawData	30
	4.1.6 WriteCalibrationRawData	31
	4.2 Read/Write through Custom Calibration R/W Interfaces	31
	4.3 CustomRW for Custom Calibration Parameters Read/Write	34
	4.3.1 CustomCalibration Example for Depth/RGB Custom Calibration	40
5	Fisheye Custom Calibration R/W.....	41
	5.1 Handling Fisheye Calibration Data with CustomRW Tool.....	41
	5.1.1 Dependency	41
	5.1.2 Read and Write Custom Fisheye Data.....	41
	5.2 Read and Write through API	43
	5.2.1 Initialize	43
	5.2.2 ReadFECustomData	44
	5.2.3 WriteFECustomData	44
	5.2.4 Example	45
6	Dynamic Calibration API Definitions	48

6.1	Attributes	50
6.2	Initialize	50
6.3	InitializeRgbCalibrator	51
6.4	AddImages	52
6.5	GetLastPhoneROILeftCamera	53
6.6	GetLastPhoneROIRightCamera	53
6.7	GetLastTargetDistance	54
6.8	AccessGridFill	54
6.9	GetLastFrameFeaturesGrid	55
6.10	GetGridLevels	55
6.11	GetGridLevelScore	55
6.12	IsGridFull	56
6.13	IsOutOfCalibration	56
6.14	GetCalibrationError	57
6.15	IsRectificationPhaseComplete	57
6.16	IsScalePhaseComplete	57
6.17	NumOfImagesCollected	57
6.18	SetIntermediateRectificationCalibration	58
6.19	GoToScalePhase	58
6.20	GetPhase	58
6.21	GetTargetedCalibrationCorrection	58
6.22	GetRGBCalibrationCorrection	59
6.23	UpdateCalibrationTables	59
6.24	GetVersion	60

Figures

Figure 2-1 Calibration Software Stack	9
Figure 2-2 Target-less Calibration Flow	15
Figure 2-3 Gimbal Flow with Target-less Calibration.....	15
Figure 2-4 Target Image	17
Figure 2-5 Target-based Dynamic Calibration.....	18
Figure 2-6 Targeted Dynamic Calibration Integrated Two Phase Flow	18
Figure 2-7 Hybrid Dynamic Calibration Integrated Two (or Three) Phase Flow	19
Figure 2-8 Depth/RGB Custom Calibration R/W with Dynamic Calibration API	21
Figure 2-9 Fisheye Custom Calibration R/W with Dynamic Calibration API	22
Figure 5-1 Read Fisheye Custom Data on Selected Device and Display on Screen	42
Figure 5-2 Read Fisheye Custom Data into a Binary File.....	42
Figure 5-3 Write Fisheye Custom Data from a Binary File to the Device	43

Revision History

Revision Number	Description	Revision Date
2.5.2.0	First document for Calibration Tool version 2.5.2.0	Jan 2018
2.6.4.0	Support RGB calibration	March 2018
2.6.8.0	Support D435i Custom Calibration Data R/W API supports IMU custom data R/W Support calibration raw data and fisheye custom data read/write	December 2018
2.8.0.0	Advanced calibration processes for robotics	March 2019
2.11.0.0	Support Intel® RealSense™ Depth Camera D455 New DC algo compatible with production calibration algo v5.1 Support Linux (Ubuntu 16.04 and Ubuntu 18.04) on ARM platforms (Nvidia Jetson TX2, Xavier, and Firefly RK3399) Fix libpng dependency issue on Ubuntu 18.04 Supports Ubuntu 18.04 kernel 5.x Calibration API is combined into Calibration Tool package	July 2020
2.11.1.0	Support Thermal Compensation on D455	April 2021
2.12.0.0	Support Intel® RealSense™ Depth Camera D405 Support Ubuntu 20.04 Detect device USB types and add warnings on USB2 devices Enhancements in custom calibration API and sample app	May 2022
2.13.1.0	Support Intel® RealSense™ Depth Camera D457 Support Ubuntu 22.04	January 2023
2.14.2.0	Support Intel® RealSense™ Depth Camera D421	December 2024

1 Scope

This document is the programmer's guide of the Calibration API for Intel® RealSense™ technology. The API is an extension of the Calibration Tools to enable users developing their own calibration applications based on Intel calibration algorithms or user's own custom algorithms on Intel® RealSense™ Product Family D400 Series devices.

The Calibration API for Intel® RealSense™ technology includes the following:

- **Dynamic Calibration API**

This is a set of interfaces and libraries to calibrate the D400 devices with the same Intel algorithms in the Intel® RealSense™ Dynamic Calibrator. The API supports both targeted and target-less calibration. Users can use the API to build their own calibration application to fit into their specific usage needs.

The API also includes custom calibration data read/write interfaces to enable calibration with user chosen non-Intel calibration algorithms.

On very limited device SKU, this API also supports custom calibration data read/write for fisheye.

- **Examples**

Several working examples are provided with source code as reference to use the Calibration API, including sources for the Intel® RealSense™ Dynamic Calibrator and CustomRW for Intel® RealSense™ technology tools.

Important Notes: Users are free to use the example code, but the Intel calibration algorithms contained in the API library is not open source and only available as binary form. The primary goal is to enable users to develop their calibration application with the embedded Intel calibration algorithm or their custom calibration algorithms.

2 Software Architecture and Calibration Flow

2.1 Software Stack

The following diagram illustrates the calibration software stack and its components.

Figure 2-1 Calibration Software Stack

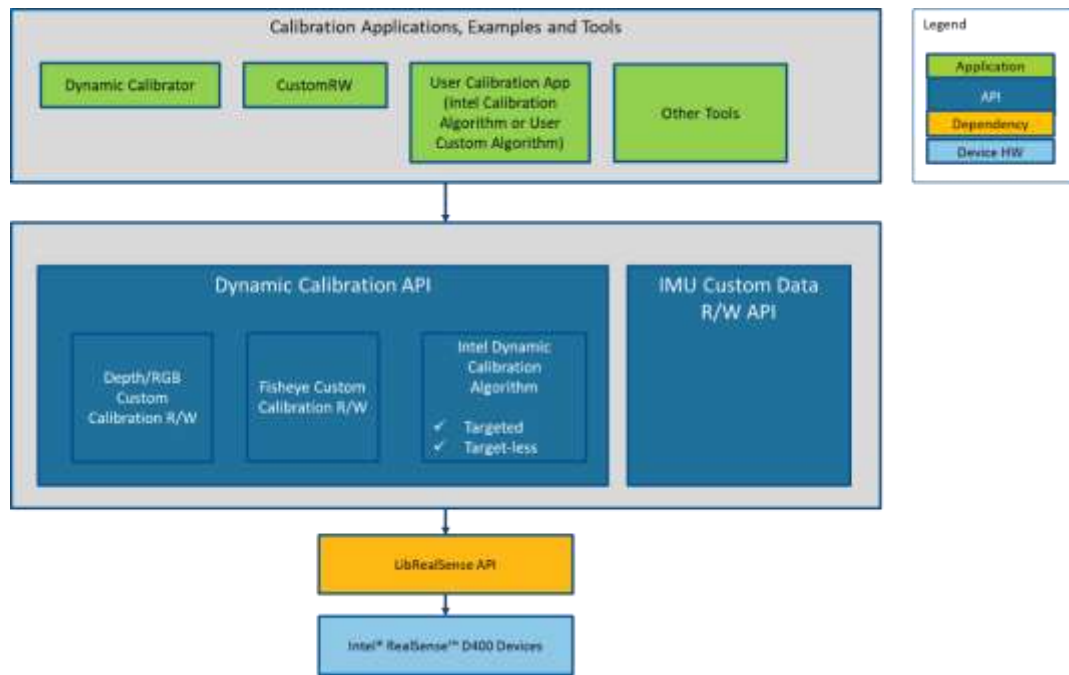

Dynamic Calibration API: A set of APIs that provide interfaces for application to use dynamic calibration algorithms in real time re-calibration. It also contains interfaces for custom calibration R/W for Depth/RGB/Fisheye.

Dynamic Calibration Algorithms: A software library that contains the real time re-calibration algorithms, for example, rectification and scale calibration.

LibRealSense API: open source camera access API for capture images, read/write to device and other camera controls.

Camera Device: Any supported Intel RealSense D400 series Depth Cameras with proper FW updated.

2.2 Calibration API

The Calibration API is part of the Calibration Tool package and can be copied from the installed directory. Please refer to chapter **Developing Custom Apps with Calibration API** in the User's Guide for details.

2.3 API Package Location

A compressed package of the interface and examples is included in the tool installation.

On **Linux:**

```

/usr
|
|----- share
|       |---- doc
|       |..... librs CalibrationTool
|       |
|       |----- api
|       |----- DynamicCalibrationAPI-Linux-2.14.2.0.tar.gz

```

On **Windows:**

```

C:\Program Files\Intel\CalibrationToolAPI
|----- 2.14.2.0
|       |
|       |----- api
|       |----- DynamicCalibrationAPI.Zip

```

2.4 API Package Structure

Copy DynamicCalibrationAPI-Linux-2.14.2.0.tar.gz or DynamicCalibrationAPI.Zip to your working folder and unzip it into similar directory structure as below:

```

DynamicCalibrationAPI
|
|----- 2.14.2.0
|       |----- CMakeLists.txt
|       |
|       |----- lib

```

Software Architecture and Calibration Flow

```

|      |      |---- libDSDynamicCalibrationAPI.so or
DSDynamicCalibrationAPI.dll
|      |
|      |..... examples
|      |      |---- DynamicCalibrator
|      |      |---- CustomRW
|      |      |---- CustomCalibration
|      |      |---- rs-calibration-converter
|      |      |---- simple-rw
|      |      |---- simple-fe
|      |
|      |----Include
|      |      |---- DSDynamicCalibration.h
|      |      |---- DSOSUtils.h
|      |      |---- DSShared.h
|      |      |---- DSCalData.h
|      |
|      |..... attributions.txt
|      |..... License.txt
|      |..... README.md
|      |..... target
|      |---- librealsense
|      |---- 3rdparty

```

Notes:

- API - libDSDynamicCalibrationAPI.so or DSDynamicCalibrationAPI.DLL is the calibration API library and DSDynamicCalibration.h is its main header file
- Under examples folder
 - ✓ DynamicCalibrator contains the source code for the Dynamic Calibrator
 - ✓ CustomRW contains the source code for the CustomRW tool
 - ✓ CustomCalibration contains sources for an example custom calibration of depth and RGB sensors with non-Intel algorithms, the example is described in detail in the *Intel RealSense Depth Module D400 Series Custom Calibration* white paper

2.5 Compiling Examples

The API package support cmake.

On Linux:

```

cd DynamicCalibrationAPI/2.14.2.0
mkdir build

```

```
cd build
cmake ..
-- The C compiler identification is GNU 5.4.0
-- The CXX compiler identification is GNU 5.4.0
-- Check for working C compiler: /usr/bin/cc
-- Check for working C compiler: /usr/bin/cc -- works
-- Detecting C compiler ABI info
-- Detecting C compiler ABI info - done
-- Detecting C compile features
-- Detecting C compile features - done
-- Check for working CXX compiler: /usr/bin/c++
-- Check for working CXX compiler: /usr/bin/c++ -- works
-- Detecting CXX compiler ABI info
-- Detecting CXX compiler ABI info - done
-- Detecting CXX compile features
-- Detecting CXX compile features - done
-- CMAKE_SYSTEM_PROCESSOR=x86_64
-- BUILD_SHARED_LIBS=ON
--
LIBRS_INCLUDE_DIR=/home/gwen/dc/test/DynamicCalibrationAPI/2.14
.2.0/librealsense/include
--
LIBRS_LIBRARY_DIR=/home/gwen/dc/test/DynamicCalibrationAPI/2.14.
2.0/librealsense/lib/linux/x86_64
--
DCAPI_INCLUDE_DIR=/home/gwen/dc/test/DynamicCalibrationAPI/2.1
4.2.0/Include
--
DCAPI_LIBRARY_DIR=/home/gwen/dc/test/DynamicCalibrationAPI/2.14
.2.0/lib
-- Configuring done
-- Generating done
-- Build files have been written to:
/home/gwen/dc/test/DynamicCalibrationAPI/2.14.2.0/build
make -j8
```

On Windows:

Config cmake for compilaing CalibrationToolAPI\2.14.2.0 and generate project files for Visual Studio 2019 and x64 platform.

Software Architecture and Calibration Flow

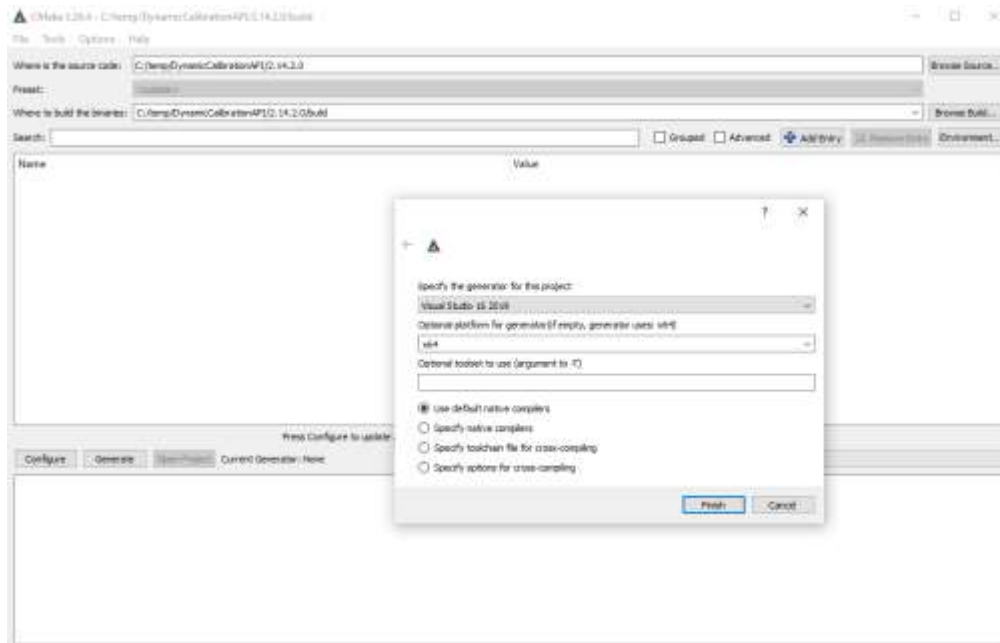

Open rs-dynamic-calibration-api-samples.sln under build directory to compile.

2.6 Calibration Parameters

A set of calibration parameters are used to describe the basic characteristics of the device.

Intrinsic includes

- Focal length - specified as [fx; fy] in pixels for left, right, and RGB cameras
- Principal point - specified as [px; py] in pixels for left, right, and RGB cameras
- Distortion - specified as Brown's distortion model [k1; k2; p1; p2; k3] for left, right, and RGB cameras

Extrinsic includes

- RotationLeftRight - rotation from right camera coordinate system to left camera coordinate system, specified as a 3x3 rotation matrix
- TranslationLeftRight - translation from right camera coordinate system to left camera coordinate system, specified as a 3x1 vector in millimeters
- RotationLeftRGB - rotation from RGB camera coordinate system to left camera coordinate system, specified as a 3x3 rotation matrix
- TranslationLeftRGB - translation from RGB camera coordinate system to left camera coordinate system, specified as a 3x1 vector in millimeters

The left camera is the reference camera and is located at world origin. RGB parameters only apply to depth modules/cameras with RGB sensor for color, e.g., D415, D435, D435i, and D455.

2.7 Dynamic Calibration with Intel Algorithms

Dynamic Calibration optimizes extrinsic parameters, i.e., they refer to calibration done in the field at the user environment with minimal or no user intervention. They are ONLY extrinsic parameters (translation and rotation) of the camera image with regard to the main axis system (the axis between the left and right). Intrinsic parameters such as distortion, field of view, and principal point are not dynamically calibrated.

Dynamic calibration is run under the assumption that it is the re-calibration of the depth modules/cameras after factory calibration or Intel OEM Calibration, or at least that the nominal parameters are known.

Two different types of dynamic calibrations algorithms are supported:

- Rectification calibration: aligning the epipolar line to enable the depth pipeline to work correctly and reduce the holes in the depth image
- Depth scale calibration: aligning the depth frame due to changes in position of the optical elements

Dynamic Calibration API supports these algorithms in two distinctive operating modes based on these algorithms: **targeted** and **target-less**, each with a different use flow.

Important Notes:

- The **Intel® RealSense™ Dynamic Calibrator** in the Calibration Tool package supports only targeted calibration.
- Targeted calibration is the recommended approach because it includes both rectification and depth scale calibrations and will give more accurate and consistent results than rectification only calibration done in target-less calibration.

2.7.1 Target-less

In target-less mode, Dynamic Calibration API supports rectification calibration without the need of any target.

Its basic flow is summarized as following:

1. Take the rectified images from L and R camera in real-time
2. Extract features from the images
3. Match the features between L and R camera

Software Architecture and Calibration Flow

4. The image is binned into 6x8 grid. Check whether each bin contains enough corresponding points.
5. The user sees the panel status and moves the device around (bins without features are blue).
6. Steps 1-6 are iterated until all bins have enough feature points
7. Check rectification error (absolute Y difference). If too large, run a solver to optimize extrinsic parameters to minimize it.

Figure 2-2 Target-less Calibration Flow

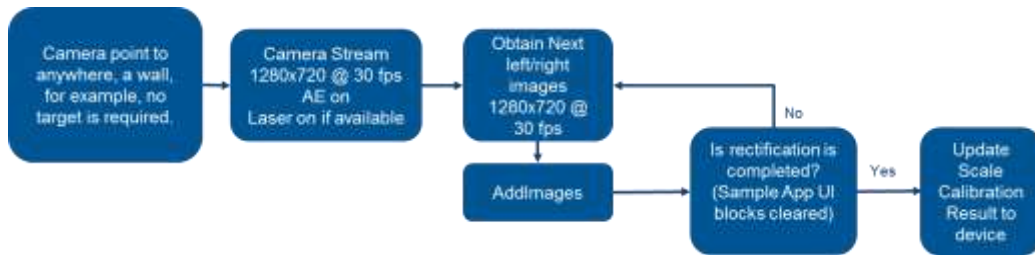

By default, target-less calibration supports 1280x720 resolution images. On devices with wide angle lenses such as D420, D430, D435, and D435i additional native resolution 1280x800 is also supported.

If Gimbal is used with target-less calibration, it will operate independently of the above flow (Figure 7-1) to move the camera automatically based on scene detection results:

Figure 2-3 Gimbal Flow with Target-less Calibration

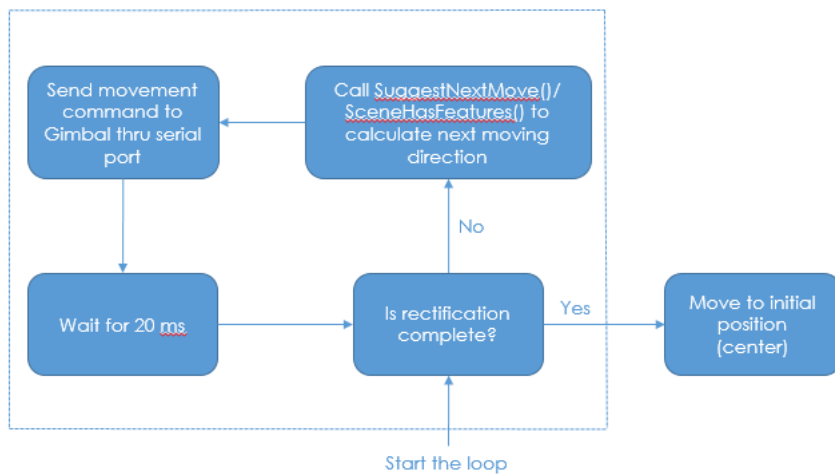

Gimbal is supported only for target-less calibration at experimental basis. Targeted calibration is not supported.

Important Notes:

- Targeted calibration is likely to give more accurate results and is therefore the recommended approach.
- The advantage of target-less calibration is simplicity, no calibration target is needed. It fits with user cases where calibrating with a target may not be feasible. The disadvantage is that it calibrates left/right depth but not RGB and generally less accurate and less consistent than targeted calibration.

2.7.2 Target-based

In targeted mode, Dynamic Calibration API supports depth scale calibration and a target is required. The target is predefined and can be printed on legal size paper or displayed on a smartphone through phone app.

An example of the target image is shown below. The printed target image is included in `print-target-fixed-width.pdf` which can be downloaded from Intel® RealSense™ product website or Intel® RealSense™ Calibration Tool package. On phone devices, the actual image is device dependent and dynamically generated at runtime through the Intel® RealSense™ Dynamic Target Tool phone app. The app is available on Apple app store or Google Play.

Figure 2-4 Target Image

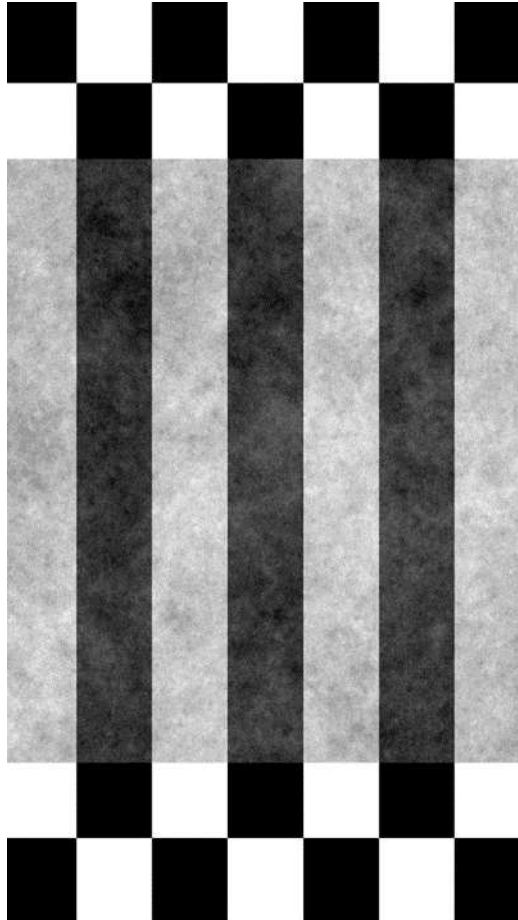

As part of the process, the application acquires images of the calibration target and feed into dynamic calibration algorithm. The process is divided into two consecutive steps: rectification phase and scale phase, as shown below. The rectification phase fixes rectification issues so the device stream is corrected with sufficient depth quality for the next phase to fix scaling issues. The process requires images from simultaneous depth, rectified left and right images at 1280x720 resolution.

Figure 2-5 Target-based Dynamic Calibration

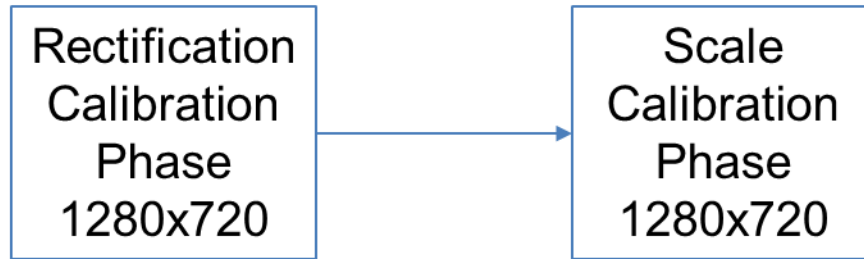
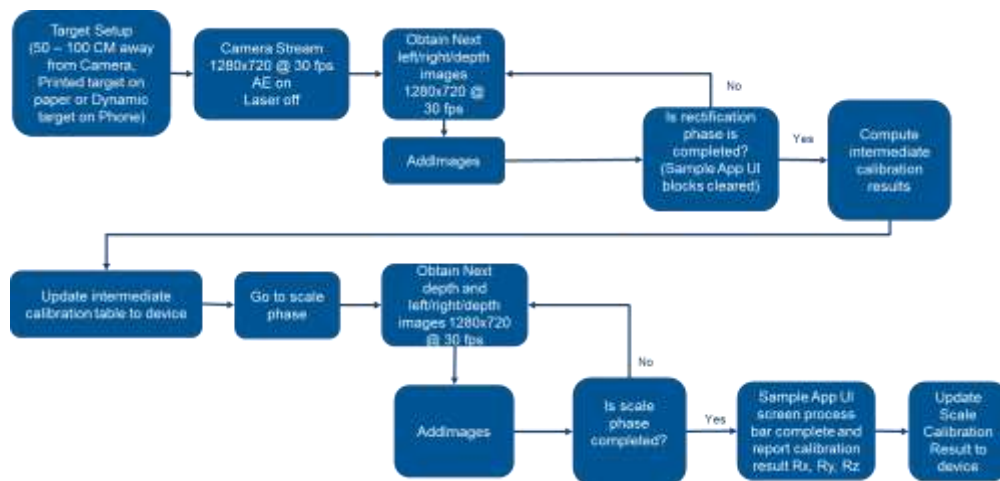

Figure 2-4 highlights a high level flow and shows how targeted dynamic calibration is implemented based on the two-phase algorithm:

- 1) Take the images from L and R camera, including the depth stream (in real-time)
- 2) Detect the calibration target in both images
- 3) User moves the printed target or phone so that it covered most of the image, repeating steps 1-2
- 4) Once done, user just keeps taking images by positioning the phone anywhere in the image but must move the phone every time
- 5) After taking 15 images in step 4, the process is complete
- 6) The process checks for rectification error (absolute Y difference) but also compares the measured pattern size with ground truth

Figure 2-6 Targeted Dynamic Calibration Integrated Two Phase Flow



The advantage of targeted calibration is that it's accurate and consistent. It calibrates left/right depth as well as RGB (on devices with RGB). The disadvantage is that it

Software Architecture and Calibration Flow

requires calibration target which means it cannot be used in cases where calibrating with a target is not feasible.

2.7.3 Hybrid

Hybrid Calibration combines best of Target-less Calibration (convenience) and Targeted Calibration (accuracy) into a single process. It starts with a target-less calibration to rectifies the left/right images and then followed with a targeted scale only calibration. It provides flexibility as well as accuracy.

Figure 2-7 Hybrid Dynamic Calibration Integrated Two (or Three) Phase Flow



2.7.4 Image Formats Used in Dynamic Calibration

Targeted Dynamic Calibration requires simultaneous images from depth, rectified left and right imagers in ZR8L8 format which is only available when the device is running under advanced mode.

Target-less Dynamic Calibration requires simultaneous rectified images from left and right imagers in ZR8L8 format.

Format	SKU	Used	Dynamic Calibration Type
ZR8L8	D400 D410 D415	Dynamic Calibration Targeted Calibration: 1280x720 @ 30 fps	Targeted Dynamic Calibration
	D420 D430 D435 D435i	Dynamic Calibration Targeted Calibration: 1280x720 @ 30 fps	
RY8_LY8 [16 bits]	D400 D410 D415	Dynamic Calibration Target-less Calibration: 1280x720 @ 30 fps or 1920x1080 @ 25 fps	Target-less Dynamic Calibration
	D420 D430 D435 D435i	Dynamic Calibration Target-less Calibration: 1280x720 @ 30 fps or 1280x800 @ 30 fps	

2.8 Depth/RGB Custom Calibration with User Algorithms

In some cases, user may prefer to calibrate the D400 devices with their own algorithms instead of the Intel algorithms, however, the calibration data will still need to be updated to the device for the optimization to take effect in actual device performance.

The Custom Calibration R/W interfaces in the Dynamic Calibration API provide mechanisms to read and write the high-level calibration parameters described in section 2.2 from/to the device. The API converts the high-level parameters into internal formats that the device can understand so user only works with those high-level parameters.

Figure 2-8 Depth/RGB Custom Calibration R/W with Dynamic Calibration API

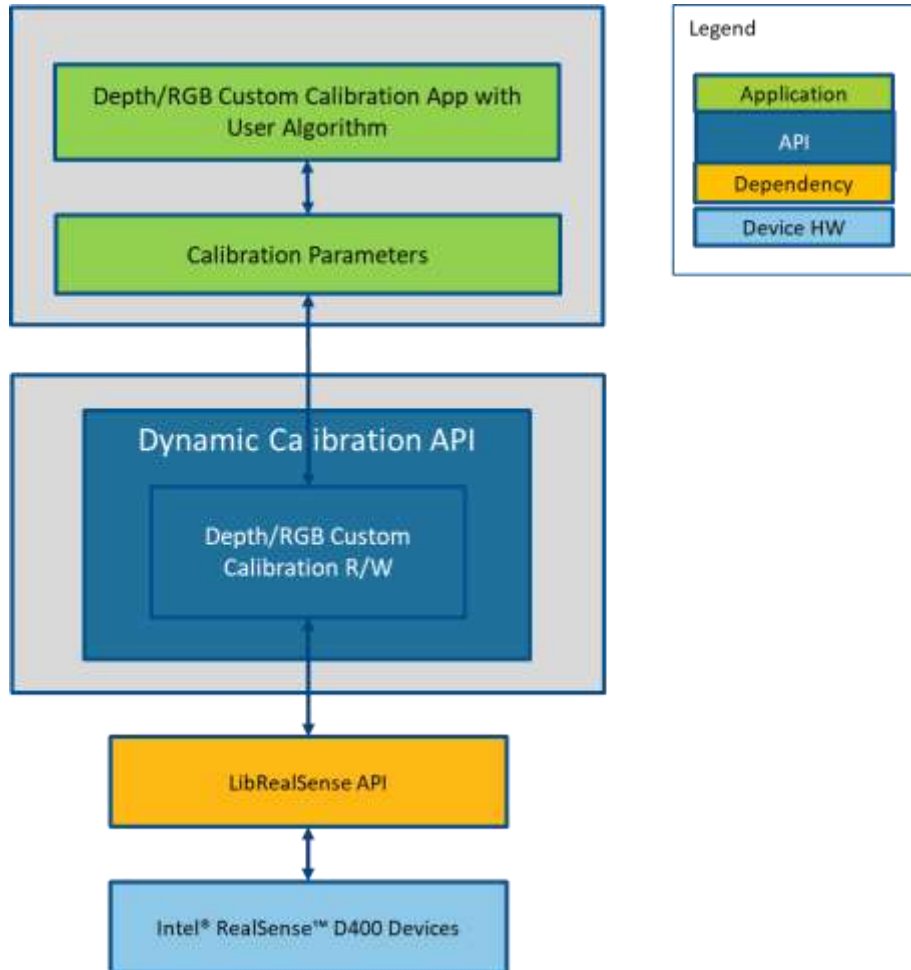

A detailed example is described in the white paper *Intel® RealSense™ Product Family D400 Series Custom Calibration* which is available on Intel® RealSense™ product website:

<https://www.intel.com/content/www/us/en/support/articles/000026725/emerging-technologies/intel-realsense-technology.html>

2.9 Fisheye Custom Calibration with User Algorithms

(Supported only on limited devices with a fisheye)

Devices in very limited SKU contains a fisheye sensor but it's not calibrated. User will need to calibrate the fisheye with their own methods and store the calibration data on the device and retrieve it later. The fisheye custom data R/W interfaces in Dynamic Calibration API provides such ability for the data storage on device. The API simply takes a byte buffer and does not restrict the exact memory layout. User is responsible for the calibration data format to write to and interpret it after read from the device through the API.

Figure 2-9 Fisheye Custom Calibration R/W with Dynamic Calibration API

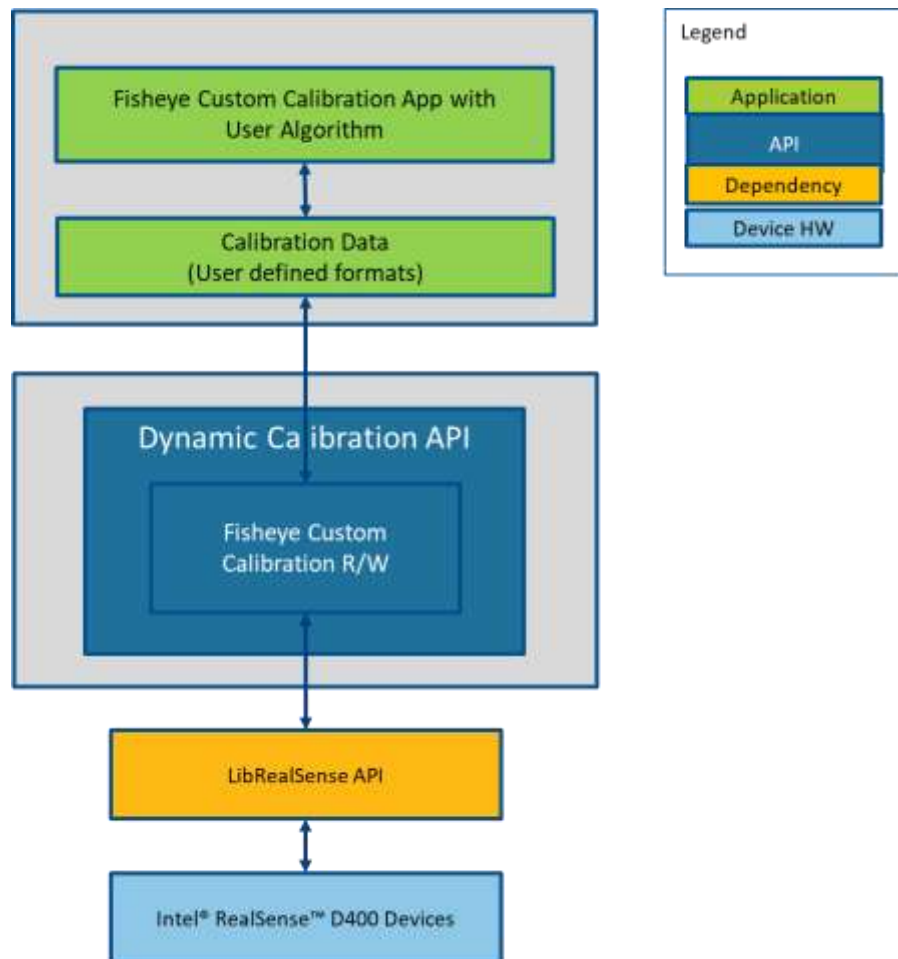

3 **Calibrating Depth/RGB with Intel Algorithm through Dynamic Calibration API**

Dynamic Calibration API supports three usage modes: Intel target-less calibration algorithm, Intel targeted calibration algorithm, and user custom calibration algorithm.

```
/** Calibration Modes */
enum CalibrationMode
{
    /** Intel target-less calibration (target-less depth rectification only)*/
    CAL_MODE_INTEL_TARGETLESS = 0,
    /** Intel targeted calibration (targeted depth rectification and targeted depth scale)*/
    CAL_MODE_INTEL_TARGETED = 1,
    /** Intel targeted depth scale calibration only */
    CAL_MODE_INTEL_TARGETED_SCALE_ONLY = 3,
    /** Intel targeted RGB calibration */
    CAL_MODE_INTEL_RGB_CALIB = 4,
    /** User custom algorithm */
    CAL_MODE_USER_CUSTOM = 99        };
```

Intel target-less calibration, Intel targeted calibration, Intel targeted scale only and RGB calibration algorithms are built into the library which user adjust parameters but cannot change the algorithm itself.

3.1 **Targeted Calibration**

The following calling sequence illustrates a simplified flow for Linux based targeted calibration which is a two-phase process: rectification and scale phase in sequential order. Please refer to API documentation and Sample app source code for details

```
// declare variable for Calibration Tool API and camera access api
DSDynamicCalibration g_Dyncal;

// get camera access handle from librealsense, for example, g_rHal
// initialize camera
// turn off laser projector (laser interferes with target images on phone screen)
// setup camera streaming resolution and frame rate for left/right/depth images
```

```

// initialize Calibration Tool API for targeted calibration
g_Dyncal.Initialize(g_rHal,
DynamicCalibrationAPI::DSDynamicCalibration::CAL_MODE_INTEL_TARGETED,
g_width, g_height, false);

// start capture with a callback function

// first phase - rectification
// in the callback function, check if calibration is completed and add images to
Calibration Tool API for processing
while (!g_Dyncal.IsGridFull())
{
    g_Dyncal.AddImages(leftImage, rightImage, depthImage, timeStamp);
}

// once first phase is completed, get the intermediate result and apply it to current
stream on device
g_Dyncal.SetIntermediateRectificationCalibration ()

// switch to second phase – scale
g_Dyncal.GoToScalePhase();
// add left/right/depth images to Calibration Tool API until scale phase is completed
while(!g_Dyncal.IsScalePhaseComplete())
{
    g_Dyncal.AddImages((uint8_t *)leftImage, (uint8_t *)rightImage, (uint16_t
*)depthImage, timeStamp);
}

// when calibration process is completed, stop capture

// get the updated calibration parameters and write to device
g_Dyncal->UpdateCalibrationTables ();

// release handles

```

3.2 Target-less Calibration

The following calling sequence illustrates a simplified flow for Linux based target-less calibration. Please refer to API documentation and sample app for details.

```

// declare variable for dynamic calibration api
DSDynamicCalibration g_Dyncal;

// get camera access handle g_rsHal

```

Calibrating Depth/RGB with Intel Algorithm through Dynamic Calibration API

```
// initialize camera
// enable laser projector if available
// setup camera streaming resolution and frame rate for left/right images

// initialize Calibration Tool API for target-less calibration with laser projector on
g_Dyncal.Initialize(g_rsHal,
DynamicCalibrationAPI::DSDynamicCalibration::CAL_MODE_INTEL_TARGETLESS,
g_width, g_height, true);

// start capture with a callback function

// in the callback function, check if calibration is completed and add images to
Calibration Tool API for processing
while (!g_Dyncal.IsGridFull())
{
    g_Dyncal.AddImages(leftImage, rightImage, depthImage, timeStamp);
}

// when calibration is completed, stop capture

// get the updated calibration parameters and write to device
g_Dyncal->UpdateCalibrationTables ();

// release handles
```

3.3 Hybrid Calibration

The following calling sequence illustrates a simplified flow for Linux based hybrid calibration. Please refer to API documentation and sample app for details.

```
// declare variable for dynamic calibration api
DSDynamicCalibration g_Dyncal;

// get camera access handle g_rsHal

// initialize camera
// enable laser projector if available
// setup camera streaming resolution and frame rate for left/right images

// initialize Calibration Tool API for target-less calibration with laser projector on
```

```
g_Dyncal.Initialize(g_rsHal,  
DynamicCalibrationAPI::DSDynamicCalibration::CAL_MODE_INTEL_TARGETLESS,  
g_width, g_height, true);  
  
// start capture with a callback function  
  
// in the callback function, check if calibration is completed and add images to  
// Calibration Tool API for processing  
while (!g_Dyncal.IsGridFull())  
{  
    g_Dyncal.AddImages(leftImage, rightImage, depthImage, timeStamp);  
}  
  
// when calibration is completed, stop capture  
  
// get the updated calibration parameters and write to device  
g_Dyncal->UpdateCalibrationTables ();  
  
// release handles  
  
// continues to targeted scale calibration  
  
// initialize camera  
// enable laser projector if available  
// setup camera streaming resolution and frame rate for depth/left/right images  
  
// initialize Calibration Tool API for targeted scale calibration with laser projector off  
g_Dyncal.Initialize(g_rsHal,  
DynamicCalibrationAPI::DSDynamicCalibration::CAL_MODE_INTEL_SCALE_ONLY,  
g_width, g_height, false);  
  
// start capture with a callback function  
  
// in the callback function, check if calibration is completed and add images to  
// Calibration Tool API for processing  
while (!g_Dyncal.IsGridFull())  
{  
    g_Dyncal.AddImages(leftImage, rightImage, depthImage, timeStamp);  
}  
  
// when calibration is completed, stop capture  
  
// get the updated calibration parameters and write to device  
g_Dyncal->UpdateCalibrationTables ();
```

```
// release handles
```

3.4 Sample Dynamic Calibrator Application

A fully operational sample application Intel® RealSense™ Dynamic Calibrator is provided to show case usage of the Dynamic Calibration API. Source code is part of the installation package under the examples directory. The application supports

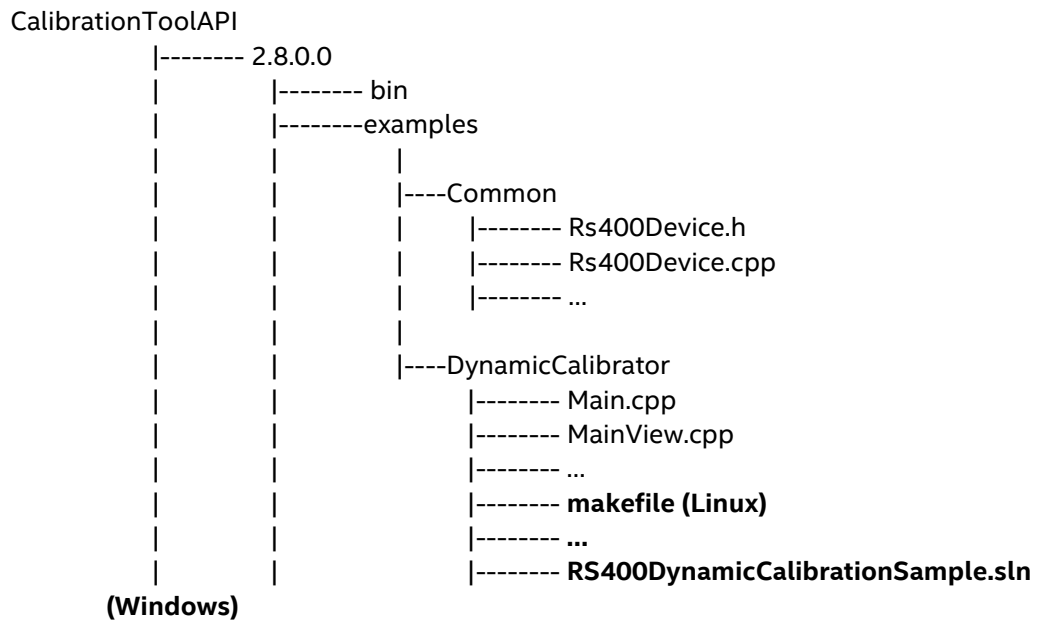

To compile the sample app

- On Windows, open RS400DynamicCalibrationSample.sln and build the project in **VisualStudio 2019**.
- On Linux, use make.

The executables DynamicCalibrator and DynamicCalibratorCLI will be located under bin directory after the sample successful compiled.

4 **Depth/RGB Custom Calibration R/W**

In cases where user calibrates the D400 device with their own algorithm, Custom Calibration R/W interfaces in Dynamic Calibration API helps to write the data to the device and read it back later. This is useful if user determines an optimized calibration algorithm that would better fit their needs than the Intel calibration algorithm can provide.

In custom calibration mode, the user is responsible for the calibration algorithm and come up with the calibration parameters for the device, the library will provide interfaces to read/write the calibration parameters to the device. The API handles all internal data formats and device operations.

Please refer to the “Intel® RealSense™ Product Family D400 Series Custom Calibration” white paper for more details.

4.1 **Interfaces**

Dynamic Calibration API provides interfaces to facilitate the depth/RGB calibration data R/W for custom calibration.

4.1.1 **Initialize**

In custom mode, the Dynamic Calibration API library should be initialized with CalibrationMode = CAL_MODE_USER_CUSTOM. For example,

```
Initialize(prs2dev,  
DynamicCalibrationAPI::DSDynamicCalibration::CAL_MODE_USER_CUSTOM)
```

where prs2dev is a pointer to librealsense rs2device handle

4.1.2 **WriteCustomCalibrationParameters**

Write calibration parameters to device

```
int WriteCustomCalibrationParameters(const int resolutionLeftRight[2], const double focalLengthLeft[2],  
const double principalPointLeft[2], const double distortionLeft[5], const double focalLengthRight[2], const  
double principalPointRight[2], const double distortionRight[5], const double rotationRight[9], const double  
translationRight[3], const bool hasRGB, const int resolutionRGB[2], const double focalLengthRGB[2], const  
double principalPointRGB[2], const double distortionRGB[5], const double rotationRGB[9], const double  
translationRGB[3]);
```

where

calibration parameters assumes that left camera is the reference camera and is located at world origin.

- resolutionLeftRight: The resolution of the left and right camera, specified as [width; height]
- focalLengthLeft: The focal length of the left camera, specified as [fx; fy] in pixels

Depth/RGB Custom Calibration R/W

- param principalPointLeft: The principal point of the left camera, specified as [px; py] in pixels
- distortionLeft: The distortion of the left camera, specified as Brown's distortion model [k1; k2; p1; p2; k3]
- focalLengthRight: The focal length of the right camera, specified as [fx; fy] in pixels
- principalPointRight: The principal point of the right camera, specified as [px; py] in pixels
- distortionRight: The distortion of the right camera, specified as Brown's distortion model [k1; k2; p1; p2; k3]
- rotationLeftRight: The rotation from the right camera coordinate system to the left camera coordinate system, specified as a 3x3 row-major rotation matrix
- translationLeftRight: The translation from the right camera coordinate system to the left camera coordinate system, specified as a 3x1 vector in millimeters
- hasRGB: Whether RGB camera calibration parameters are supplied
- resolutionRGB: The resolution of the RGB camera, specified as [width; height]
- focalLengthRGB: The focal length of the RGB camera, specified as [fx; fy] in pixels
- principalPointRGB: The principal point of the RGB camera, specified as [px; py] in pixels
- distortionRGB: The distortion of the RGB camera, specified as Brown's distortion model [k1; k2; p1; p2; k3]
- rotationLeftRGB: The rotation from the RGB camera coordinate system to the left camera coordinate system, specified as a 3x3 row-major rotation matrix
- translationLeftRGB: The translation from the RGB camera coordinate system to the left camera coordinate system, specified as a 3x1 vector in millimeters

returns When DC_SUCCESS then the tables were created successfully, otherwise, returns error code

- * DC_ERROR_CUSTOM_INVALID_CAL_TABLE - one or more of the calibration tables are not valid
- * DC_ERROR_CUSTOM_INVALID_LEFTRIGHT_RESOLUTION - left and right camera resolution is not supported
- * DC_ERROR_CUSTOM_LEFT_INTRINSICS_UNREASONABLE - left camera intrinsics unreasonable
- * DC_ERROR_CUSTOM_RIGHT_INTRINSICS_UNREASONABLE - right camera intrinsics unreasonable

4.1.3 ReadCalibrationParameters

Read calibration parameters from device

```
int ReadCalibrationParameters(int resolutionLeftRight[2], double focalLengthLeft[2], double
principalPointLeft[2], double distortionLeft[5], double focalLengthRight[2], double principalPointRight[2],
double distortionRight[5], double rotationRight[9], double translationRight[3], bool& hasRGB, int
resolutionRGB[2], double focalLengthRGB[2], double principalPointRGB[2], double distortionRGB[5], double
rotationRGB[9], double translationRGB[3]);
```

where

- calibration parameters assumes that left camera is the reference camera and is located at world origin.
- resolutionLeftRight: The resolution of the left and right camera, specified as [width; height]
- focalLengthLeft: The focal length of the left camera, specified as [fx; fy] in pixels
- param principalPointLeft: The principal point of the left camera, specified as [px; py] in pixels
- distortionLeft: The distortion of the left camera, specified as Brown's distortion model [k1; k2; p1; p2; k3]

- focalLengthRight: The focal length of the right camera, specified as [fx; fy] in pixels
- principalPointRight: The principal point of the right camera, specified as [px; py] in pixels
- distortionRight: The distortion of the right camera, specified as Brown's distortion model [k1; k2; p1; p2; k3]
- rotationLeftRight: The rotation from the right camera coordinate system to the left camera coordinate system, specified as a 3x3 row-major rotation matrix
- translationLeftRight: The translation from the right camera coordinate system to the left camera coordinate system, specified as a 3x1 vector in millimeters
- hasRGB: Whether RGB camera calibration parameters are supplied
- resolutionRGB: The resolution of the RGB camera, specified as [width; height]
- focalLengthRGB: The focal length of the RGB camera, specified as [fx; fy] in pixels
- principalPointRGB: The principal point of the RGB camera, specified as [px; py] in pixels
- distortionRGB: The distortion of the RGB camera, specified as Brown's distortion model [k1; k2; p1; p2; k3]
- rotationLeftRGB: The rotation from the RGB camera coordinate system to the left camera coordinate system, specified as a 3x3 row-major rotation matrix
- translationLeftRGB: The translation from the RGB camera coordinate system to the left camera coordinate system, specified as a 3x1 vector in millimeters

returns When DC_SUCCESS then the tables were created successfully, otherwise, returns error code

- DC_ERROR_CUSTOM_INVALID_CAL_TABLE - one or more of the calibration tables are not valid
- DC_ERROR_CUSTOM_INVALID_PARAMS - one or more of the output calibration parameters are not valid

4.1.4 ResetDeviceCalibration

Reset active calibration data on device to desired settings

```
int ResetDeviceCalibration(CalibrationSettings setting = CalibrationSettings::CAL_SETTINGS_GOLD);
```

where

setting: currently only CalibrationSettings::CAL_SETTINGS_GOLD is valid, depends on the calibrations performed on the device, this setting came from either factory calibration or OEM calibration

return When DC_SUCCESS then calibration is reset to the desired setting

- DC_ERROR_INVALID_CAL_SETTINGS - invalid setting provided
- DC_ERROR_FAIL - failed to restore to the desired setting

4.1.5 ReadCalibrationRawData

Read calibration table raw data from device into buffer

```
int ReadCalibrationRawData(uint8_t* table, CalibrationTableType tableType);
```

Where

Depth/RGB Custom Calibration R/W

Table is user allocated buffer in type dependent size of DC_CALIB_COEFF_TABLE_SIZE, DC_CALIB_DEPTH_TABLE_SIZE, or DC_CALIB_RGB_TABLE_SIZE

tableType is calibration table type including CAL_TABLE_COEFF, CAL_TABLE_DEPTH, CAL_TABLE_RGB

and return DC_SUCCESS when raw data read successfully, otherwise, in error conditions

- DC_ERROR_NOT_INITIALIZED - library not initialized
- DC_ERROR_INVALID_BUFFER - invalid buffer
- DC_ERROR_INVALID_CAL_TABLE_TYPE - unsupported table type
- DC_ERROR_FAIL - failed to read the raw data from the device

4.1.6 WriteCalibrationRawData

Write calibration table raw data to device

```
int WriteCalibrationRawData(uint8_t* table, CalibrationTableType tableType);
```

Where

table: user allocated buffer in type dependent size of DC_CALIB_COEFF_TABLE_SIZE, DC_CALIB_DEPTH_TABLE_SIZE, or DC_CALIB_RGB_TABLE_SIZE.. The table content usually is saved from a device or generated from other Intel RealSense tools.

tableType: calibration table type including CAL_TABLE_COEFF, CAL_TABLE_DEPTH, CAL_TABLE_RGB

It returns DC_SUCCESS when raw data write successfully, otherwise, error conditions

- DC_ERROR_NOT_INITIALIZED - library not initialized
- DC_ERROR_INVALID_BUFFER - invalid buffer
- DC_ERROR_INVALID_CAL_TABLE_TYPE - unsupported table type
- DC_ERROR_FAIL - failed to write the raw data to the device

4.2 Read/Write through Custom Calibration R/W Interfaces

```
// Get libRealSense device handle for the D400 device
```

```
Rs400Device *g_rsDevice = new Rs400Device();
```

```
void *g_pDevice = g_rsDevice->GetDeviceHandle();
```

```
// Initialize the camera device
```

```
g_rsDevice->InitializeCamera();
```

```
// The expected calibration parameters for D400 series devices are defined as following:
```

```
// resolutionLeftRight: The resolution of the left and right camera, specified as[width; height]
```

```
// focalLengthLeft : The focal length of the left camera, specified as[fx; fy] in pixels
```

```
// principalPointLeft : The principal point of the left camera, specified as[px; py] in pixels
```

```

// distortionLeft : The distortion of the left camera, specified as Brown's distortion
// model [k1; k2; p1; p2; k3]
//
// focalLengthRight : The focal length of the right camera, specified as[fx; fy] in pixels
// principalPointRight : The principal point of the right camera, specified as[px; py] in
// pixels
// distortionRight : The distortion of the right camera, specified as Brown's distortion
// model [k1; k2; p1; p2; k3]
// rotationLeftRight : The rotation from the right camera coordinate system to the left
// camera coordinate system, specified as a 3x3 rotation matrix
// translationLeftRight : The translation from the right camera coordinate system to
// the left camera coordinate system, specified as a 3x1 vector in millimeters
//
// hasRGB : Whether RGB camera calibration parameters are supplied
// resolutionRGB : The resolution of the RGB camera, specified as[width; height]
// focalLengthRGB : The focal length of the RGB camera, specified as[fx; fy] in pixels
// principalPointRGB : The principal point of the RGB camera, specified as[px; py] in
// pixels
// distortionRGB : The distortion of the RGB camera, specified as Brown's distortion
// model [k1; k2; p1; p2; k3]
// rotationLeftRGB : The rotation from the RGB camera coordinate system to the left
// camera coordinate system, specified as a 3x3 rotation matrix
// translationLeftRGB : The translation from the RGB camera coordinate system to the
// left camera coordinate system, specified as a 3x1 vector in millimeters
//
bool hasRGB;
int resolutionLeftRight[2], resolutionRGB[2];
double focalLengthLeft[2], focalLengthRight[2], focalLengthRGB[2];
double principalPointLeft[2], principalPointRight[2], principalPointRGB[2];
double distortionLeft[5], distortionRight[5], distortionRGB[5];
double rotationLeftRight[9], rotationLeftRGB[9];
double translationLeftRight[3], translationLeftRGB[3];

// Perform calibration with user custom algo here including
// calibration stream setup and frame capture
// calibration computation with custom algo
// obtain optimized calibration parameters
//
// ***** A LOT OF YOUR CODE HERE for custom calibration *****
//
// An example of the parameter from a D400 device
// resolutionLeftRight: 1920 1080
//
// FocalLengthLeft : 1365.328979 1372.806641
// PrincipalPointLeft : 959.393311 536.781494

```

Depth/RGB Custom Calibration R/W

```
// DistortionLeft: 0.130178 - 0.393367 - 0.000580 0.001172 0.326398
//
// FocalLengthRight: 1371.838989 1379.178101
// PrincipalPointRight: 961.465759 540.101624
// DistortionRight: 0.121403 - 0.385616 - 0.001131 - 0.000172 0.325395
//
// RotationLeftRight: 0.999980 0.000408 - 0.006359
// - 0.000443 0.999985 - 0.005404
// 0.006357 0.005407 0.999965
// TranslationLeftRight: -55.109779 - 0.111518 - 0.114459
// HasRGB : 0
//
// Another example of the parameters from a D435 device
//
// resolutionLeftRight : 1280 800
//
// FocalLengthLeft : 639.322205 637.623474
// PrincipalPointLeft : 645.968262 399.232727
// DistortionLeft : -0.057135 0.067378 0.000959 - 0.000607 - 0.021941
//
// FocalLengthRight : 640.831848 639.201416
// PrincipalPointRight : 641.968384 405.641235
// DistortionRight : -0.056585 0.065952 0.000865 - 0.000556 - 0.021422
//
// RotationLeftRight : 0.999997 - 0.001835 - 0.001385
// 0.001835 0.999998 - 0.000234
// 0.001385 0.000232 0.999999
// TranslationLeftRight : -50.030815 - 0.005517 0.060515
//
// HasRGB : 1
// resolutionRGB : 1920 1080
// FocalLengthColor : 1376.079590 1375.954102
// PrincipalPointColor : 947.814758 543.885315
// DistortionColor : 0.000000 0.000000 0.000000 0.000000 0.000000
// RotationLeftColor : 0.999981 - 0.003833 0.004792
// 0.003843 0.999990 - 0.002125
// - 0.004784 0.002143 0.999986
// TranslationLeftColor : 14.624806 0.352931 0.213506
//
```

```
// Initialize Calibration Tool API to custom calibration mode
```

```

DynamicCalibrationAPI::DSDynamicCalibration *m_dcApi = new
DSDynamicCalibration();
int ret = m_dcApi->Initialize(g_pDevice,
DynamicCalibrationAPI::DSDynamicCalibration::CAL_MODE_USER_CUSTOM);

int status = DC_SUCCESS;

//
// Write the optimized calibration parameters to device. This will alter the calibration on
// your device, please uncomment the following code only when necessary./
status = m_dcApi->WriteCustomCalibrationParameters(resolutionLeftRight,
focalLengthLeft, principalPointLeft, distortionLeft, focalLengthRight,
principalPointRight, distortionRight, rotationLeftRight, translationLeftRight, hasRGB,
resolutionRGB, focalLengthRGB, principalPointRGB, distortionRGB, rotationLeftRGB,
translationLeftRGB);

// Read back from device to confirm
status = m_dcApi->ReadCalibrationParameters(resolutionLeftRight, focalLengthLeft,
principalPointLeft, distortionLeft, focalLengthRight, principalPointRight, distortionRight,
rotationLeftRight, translationLeftRight, hasRGB, resolutionRGB, focalLengthRGB,
principalPointRGB, distortionRGB, rotationLeftRGB, translationLeftRGB);

// verify parameters
...

// Release device handle
delete g_rsDevice;
return EXIT_SUCCESS;

```

4.3 CustomRW for Custom Calibration Parameters Read/Write

A simple example CustomRW is provided to show case support calibration with user custom algo and usage of the calibration parameters read/write interfaces. Source code is part of the installation package under the examples directory.

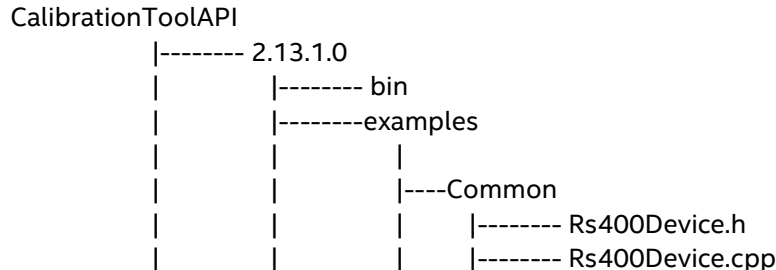

Depth/RGB Custom Calibration R/W

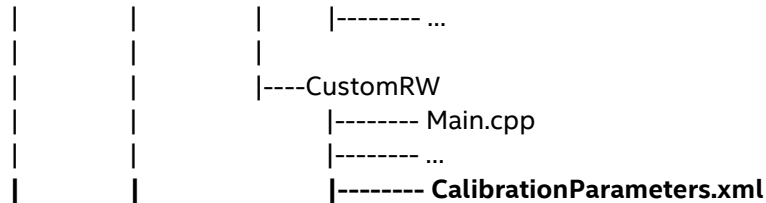

The executables CustomRW will be located under bin directory after the example successful compiled. CustomRW supports two command line options: -r and -w.

The -r option is used to read the calibration parameters from the device and dump to the screen console. -w is used to write the user calibration parameters from an XML file to the device.

For example,

```
C:\DynamicCalibrationAPI\2.14.2.0\build\Release>customrw
CustomRW for Intel RealSense D400, Version: 2.14.2.0
```

`--help`

`-?`

display list of command line options

`--list`

`-l`

display list of connected cameras

`--version`

`-v`

show dynamic calibration version info

`--sn <device serial number>`

`-sn <device serial number>`

if multiple cameras connected to the current system, choose one of the cameras to modify by specifying its serial number

`--reset-to-gold`

`-g`

Reset calibration on device to default gold factory settings

--read
-r
Read calibration data

--write
-w
Write calibration data

-raw <19, 1f, 20, or ff>
-raw <19, 1f, 20, or ff>
dump calibration table raw binary content

--file <file name>
-f <file name>
use the specified file for calibration data input or output

-fe
fisheye custom data (limited, available ONLY on selected device SKU)

--force-rgb
-rgb
force read/write rgb calibration data even if device does not have rgb sensor (for 3rd party rgb custom calibration)

--extra
-ex
print extra calibration information to console

Usages:

Example #1: reset device calibration to gold settings

customrw -g

Example #2: read device calibration and display to terminal in xml format

customrw -r

Example #3: read device calibration into a text file in xml format

customrw -r -f mydevice.xml

Depth/RGB Custom Calibration R/W

Example #4: write custom calibration from a text file in xml format into the device

```
customrw -w -f mycustomdata.xml
```

Example #5: read raw calibration table from device and display to the terminal, supported table id 19, 1F, and 20, for example,

```
customrw -r -raw 19
```

Example #6: read raw calibration table from device and save into a binary file, supported table id 19, 1F, and 20, for example,

```
customrw -r -raw 19 -f mytable-19.bin
```

Example #7: write raw calibration table from binary file into the device, supported table id 19, 1F, and 20, for example,

```
customrw -w -raw 19 -f mytable-19.bin
```

Example #8: read custom fisheye data from device and display to the terminal

```
customrw -r -fe
```

Example #9: read custom fisheye data from device and save into a binary file

```
customrw -r -fe -f myfe.bin
```

Example #10: write custom fisheye data from binary file into the device

```
customrw -w -fe -f myfe.bin
```

Example #11: read calibration data from device and print extra calibration information

```
customrw -r -ex
```

```
C:\DynamicCalibrationAPI\2.14.2.0\build\Release >
```

The -w option will alter calibration data on your device. If incorrect parameters are written, your device accuracy may be reduced or even malfunction. So please do so only when you really need to change calibration on your device.

An example of the calibration parameter XML file **CalibrationParameters.xml** is supplied in the CustomRW folder. This file is created for a D415 device. The parameters are described in section 2.1 Dynamic Calibration Parameters and also in documentation of the WriteCustomCalibrationParameters and

ReadCalibrationParameters APIs in section 9.22 and 9.23. User will need to create the calibration parameter XML file with custom data for their device.

```
<?xml version="1.0"?>
<Config>
  <param name = "ResolutionLeftRight">
    <value>1920</value>
    <value>1080</value>
  </param>
  <param name = "FocalLengthLeft">
    <value>1378.69</value>
    <value>1379.13</value>
  </param>
  <param name = "PrincipalPointLeft">
    <value>965.562</value>
    <value>542.603</value>
  </param>
  <param name = "DistortionLeft">
    <value>0.09689</value>
    <value>-0.0235634</value>
    <value>-5.05513e-05</value>
    <value>0.000105855</value>
    <value>-0.640377</value>
  </param>
  <param name = "FocalLengthRight">
    <value>1389.55</value>
    <value>1390.1</value>
  </param>
  <param name = "PrincipalPointRight">
    <value>957.402</value>
    <value>553.108</value>
  </param>
  <param name = "DistortionRight">
    <value>0.123289</value>
    <value>-0.290911</value>
    <value>0.000149083</value>
    <value>0.000723527</value>
    <value>0.0992178</value>
  </param>
  <param name = "RotationLeftRight">
    <value>0.999983</value>
    <value>0.00150008</value>
    <value>-0.00558928</value>
    <value>-0.00150249</value>
    <value>0.999999</value>
    <value>-0.000428313</value>
  </param>
</Config>
```

Depth/RGB Custom Calibration R/W

```

    <value>0.00558863</value>
    <value>0.000436704</value>
    <value>0.999984</value>
  </param>
  <param name = "TranslationLeftRight">
    <value>-55.3888</value>
    <value>0.0448052</value>
    <value>1.52189</value>
  </param>
  <param name = "HasRGB">
    <value>1</value>
  </param>
  <param name = "ResolutionRGB">
    <value>1920</value>
    <value>1080</value>
  </param>
  <param name = "FocalLengthRGB">
    <value>1376.09</value>
    <value>1376.4</value>
  </param>
  <param name = "PrincipalPointRGB">
    <value>947.958</value>
    <value>531.068</value>
  </param>
  <param name = "DistortionRGB">
    <value>0.109862</value>
    <value>-0.122685</value>
    <value>-0.000453445</value>
    <value>-8.61456e-05</value>
    <value>-0.396171</value>
  </param>
  <param name = "RotationLeftRGB">
    <value>0.999994</value>
    <value>0.00346622</value>
    <value>0.000876088</value>
    <value>-0.00346642</value>
    <value>0.999994</value>
    <value>0.000222113</value>
    <value>-0.000875313</value>
    <value>-0.000225148</value>
    <value>1</value>
  </param>
  <param name = "TranslationLeftRGB">
    <value>14.6987</value>
    <value>-0.0644999</value>
    <value>0.448085</value>
  </param>
</Config>

```

4.3.1 CustomCalibration Example for Depth/RGB Custom Calibration

A comprehensive example CustomCalibration is provided to show case support calibration with user custom algo and device setup for calibration. Source code is part of the installation package under the *examples* directory.

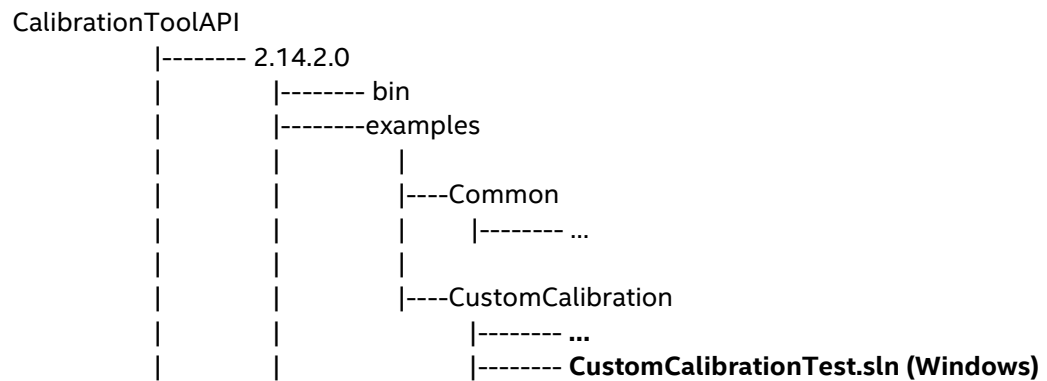

This example requires installation of OpenCV 3.3.1. It takes some setup to compile the example app.

Please refer to the white paper “**Intel® RealSense™ Product Family D400 Series Custom Calibration**” for details.

5 Fisheye Custom Calibration R/W

Important Notes:

Fisheye custom Calibration R/W is only supported on limited devices with a fisheye, i.e., Intel RealSense D430 with Tracking Module

On devices with Fisheye, the Fisheye itself is not initially calibrated, user will need to calibrate it with their own methods and then write the calibration data to the device and read it back for use later.

There are two ways to read/write into this fisheye custom calibration data storage on the device:

- 1) Read/write through the Intel.Realsense.CustomRW Tool
- 2) User develop their own tool through the Fisheye Custom Calibration R/W interfaces in the Dynamic Calibration API

5.1 Handling Fisheye Calibration Data with CustomRW Tool

The Intel.Realsense.CustomRW Tool provides users the ability to read/write custom data to the device. For fisheye data, it takes a binary input file and write it to the device. It also can read it back and display on console or save into a binary file. The file size should be 136 bytes in exact, same as the fisheye custom data storage on the device.

5.1.1 Dependency

The Intel.Realsense.CustomRW Tool is statically linked. No dependency other than the C++ runtime.

5.1.2 Read and Write Custom Fisheye Data

The `-fe` option supports read/write the custom Fisheye data on devices of limited SKU. This option should only be used on those devices.

Example: read custom Fisheye data from device and display to the terminal
`Intel.Realsense.CustomRW.exe -r -fe`

Figure 5-1 Read Fisheye Custom Data on Selected Device and Display on Screen

```

gwen@gwen-desktop: ~
gwen@gwen-desktop:~$ /usr/bin/Intel.Realsense.CustomRW -r -fe
CustomRW for Intel RealSense D400, Version: 2.6.8.0

Device PID: 0AD5
Device name: Intel RealSense D430 with Tracking Module
Serial number: 701512070239
Firmware version: 05.10.15.00
5.39.0.0

buffer size: 136 bytes

Offset (h) 00 01 02 03 04 05 06 07 08 09 0A 0B 0C 0D 0E 0F
-----
000000 ==> 00 00 C0 FF 00 00 80 3F 00 00 00 00 00 00 00 00
000010 ==> 00 00 00 00 00 00 80 3F 00 00 00 00 00 00 00 00
000020 ==> 00 00 00 00 00 00 80 3F 00 00 00 00 00 00 00 00
000030 ==> 00 00 00 00 BA 01 5F BD 94 93 81 BD D1 2A D0 BE
000040 ==> BA A6 81 3F 1A 64 83 3F DA FD 82 3F 3E 68 E9 3A
000050 ==> 30 5A F3 BA E5 36 85 3B B9 B6 80 3F 66 A0 7E 3F
000060 ==> 5A B2 7E 3F FF FF FF FF FF FF FF FF FF FF FF
000070 ==> FF FF FF FF FF FF FF FF FF FF FF FF FF FF FF
000080 ==> FF 12 34 56 78 FF FF FF
gwen@gwen-desktop:~$ █

```

Example: read custom Fisheye data from device and save into a binary file
 Intel.Realsense.CustomRW.exe -r -fe -f myfe.bin

Figure 5-2 Read Fisheye Custom Data into a Binary File

```

gwen@gwen-desktop: ~
gwen@gwen-desktop:~$ /usr/bin/Intel.Realsense.CustomRW -r -fe -f myfe.bin
CustomRW for Intel RealSense D400, Version: 2.6.8.0

Device PID: 0AD5
Device name: Intel RealSense D430 with Tracking Module
Serial number: 701512070239
Firmware version: 05.10.15.00
5.39.0.0

fe custom data on device successfully read into file myfe.bin
gwen@gwen-desktop:~$ ls -li myfe.bin
9182061 -rw-rw-r-- 1 gwen gwen 136 Dec 7 11:34 myfe.bin
gwen@gwen-desktop:~$ █

```

Fisheye Custom Calibration R/W

Example: write a Fisheye custom calibration binary data file into the device. When user calibrate the device, the results should be saved in a binary file of 136 bytes in size, then use the tool to write it into the device, or if user saved a backup from the device earlier, the same write option can restore the backup to the device.

```
Intel.Realsense.CustomRW.exe -w -fe -f myfe.bin
```

Figure 5-3 Write Fisheye Custom Data from a Binary File to the Device

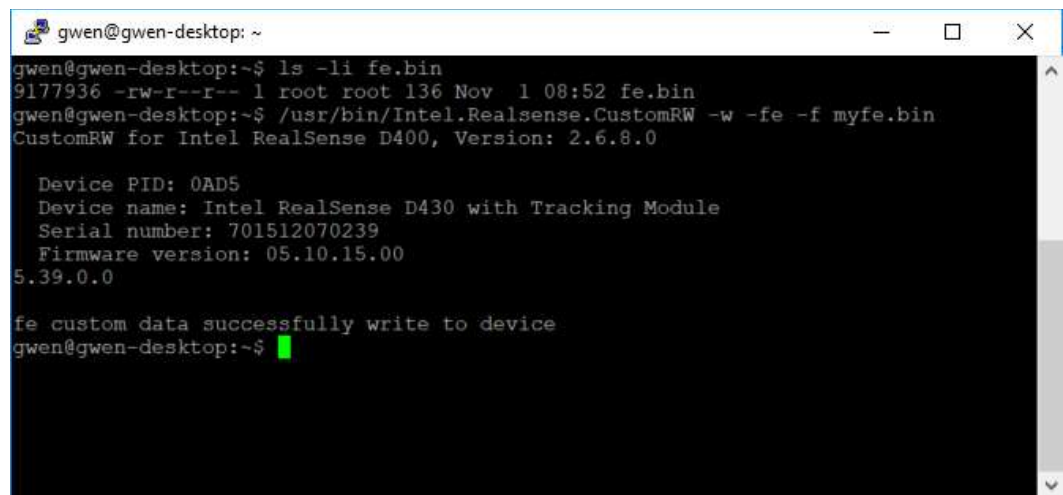

5.2 Read and Write through API

The API read the custom data from device and pass it over to the user through a user provided buffer. Similarly, user pass a buffer with the custom data to the API and write it to the device. The size of the buffer should be 136 bytes.

5.2.1 Initialize

In custom mode, the Dynamic Calibration API library should be initialized with CalibrationMode = CAL_MODE_USER_CUSTOM.

For example,

```
Initialize(prs2dev,
DynamicCalibrationAPI::DSDynamicCalibration::CAL_MODE_USER_CUSTOM)
```

where `prs2dev` is a pointer to librealsense `rs2::device` handle.

Important Notes:

Before initializing and using the API, the device which `rs2::device` points to should be running in advanced mode. The example in the next section shows the details.

5.2.2 ReadFECustomData

Read fisheye custom data from device into buffer. User is responsible for allocating and deallocating the buffer memory.

```
int ReadFECustomData(uint8_t* buffer);
```

where

`buffer`: user allocated buffer in size of `DC_MM_FE_CUSTOM_DATA_SIZE` (136 bytes)

and returns `DC_SUCCESS` when data read successfully, otherwise, errors

- `DC_ERROR_NOT_INITIALIZED` - library not initialized
- `DC_ERROR_INVALID_BUFFER` - invalid buffer
- `DC_ERROR_FAIL` - failed to read data from the device

5.2.3 WriteFECustomData

Write FE custom data buffer to device. User is responsible for allocating and deallocating the buffer memory.

```
int WriteFECustomData(uint8_t* buffer);
```

where

`buffer`: user allocated buffer in size of `DC_MM_FE_CUSTOM_DATA_SIZE` (136 bytes) that contains custom data to be written to device

and returns `DC_SUCCESS` then data written successfully, otherwise, returns errors

Fisheye Custom Calibration R/W

- DC_ERROR_NOT_INITIALIZED - library not initialized
- DC_ERROR_INVALID_BUFFER - invalid buffer
- DC_ERROR_FAIL - failed to write data to device

5.2.4 Example

A simple example is provided as part of the API package under the examples/simple-fe folder.

```

// rs context
rs2::context *ctx = new context();

// query devices on host
auto devices = ctx->query_devices();
rs2::device mydev = devices[0];

// to use the custom calibration read/write api, the device should be in advanced
mode
if (mydev.is<rs400::advanced_mode>())
{
    rs400::advanced_mode advanced = mydev.as<rs400::advanced_mode>();
    if (!advanced.is_enabled())
    {
        advanced.toggle_advanced_mode(true);
    }
}

// initialize custom calibration R/W API
MMCalibrationRWAPI *m_dcApi = new MMCalibrationRWAPI();

// mydev should be a pointer to rs2::device from librealsense
int ret = m_dcApi->Initialize(&mydev);

uint8_t mmCustom[DC_MM_CUSTOM_DATA_SIZE];

// the custom data area has DC_MM_CUSTOM_DATA_SIZE (504 bytes) of storage
space. User can
// define their data own format and write to the device and retrieve it later from
// the device

// on a new device, the storage is not initialized, so should write data before perform

```

```
// read. reading before writing any data will fail.  
// write some data as example  
memset((void*)&mmCustom, 0xFF, sizeof(mmCustom));  
mmCustom[160] = 0xB;  
mmCustom[180] = 0x8;  
  
ret = m_dcApi->WriteMMCustomData((uint8_t*) &mmCustom);  
....  
  
// read the custom data back from the device  
ret = m_dcApi->ReadMMCustomData(mmCustom);  
  
// interpret and use the calibration data in app
```

Appendix

6 Dynamic Calibration API Definitions

Calibration APIs provide interfaces for application to access dynamic calibrator for real time re-calibration and also provides APIs to read/write/restore calibration data on the device.

The API is defined in DSDynamicCalibration.h.

For Linux and Windows x64 environment, DSDynamicCalibration Class is defined under namespace DynamicCalibrationAPI.

Calibration Tool API support three calibration modes:

- Intel Targetless Calibration
- Intel Targeted Calibration
- User Custom

Both Targetless and Targeted uses Intel algorithm that embedded in the API. Custom mode enables advanced user who prefer to use their own calibration algorithm and write/read the optimized calibration parameters to the device.

```
/** Calibration Modes */
enum CalibrationMode
{
    /** Intel target-less calibration (target-less depth rectification only)*/
    CAL_MODE_INTEL_TARGETLESS = 0,
    /** Intel targeted calibration (targeted depth rectification and targeted depth
scale)*/
    CAL_MODE_INTEL_TARGETED = 1,
    /** Intel targeted depth scale calibration only */
    CAL_MODE_INTEL_TARGETED_SCALE_ONLY = 3,
    /** Intel targeted RGB calibration */
    CAL_MODE_INTEL_RGB_CALIB = 4,
    /** User custom algorithm */
    CAL_MODE_USER_CUSTOM = 99};

/** Calibration Settings */
enum CalibrationSettings
{
```

Dynamic Calibration API Definitions

```

    /** gold settings */
    CAL_SETTINGS_GOLD = 0
};

```

Grid level enumeration quantifies the amount of the features in each cell of the grid.

```

enum GridLevel
{
    /* Low amount of features in the cell */
    GRID_LEVEL_LOW = 0,
    /* Medium amount of features in the cell */
    GRID_LEVEL_MEDIUM = 1,
    /* High amount of features in the cell */
    GRID_LEVEL_HIGH = 2,
    /* Very High amount of features in the cell */
    GRID_LEVEL_VERY_HIGH = 3,
    /* Not tracked */
    GRID_LEVEL_NOT_TRACKED = 255
};

```

Grid fill enumeration quantifies how the cells are filled with features in the next frame.

```

enum GridFill
{
    /* Normal - features are subject to aging if they are in the buffer for too long */
    GRID_FILL_NORMAL = 0,
    /* Add only - will retain any existing features but keeps adding new features until the
    buffer is full */
    GRID_FILL_ADD_ONLY = 1,
    /* Cell full - will retain any existing features and not add any new features and the
    feature detection isn't run in the cell */
    GRID_FILL_CELL_FULL = 2
};

```

Grid features enumeration quantifies the amount of the features in the last frame.

```

enum GridFeatures
{
    /* Level 0 - no to little amount features */

```

```
GRID_FEATURES_L0 = 0,  
    /* Level 1 - moderate amount of features */  
    GRID_FEATURES_L1 = 1,  
    /* Level 2 - good amount of features */  
    GRID_FEATURES_L2 = 2  
};
```

6.1 Attributes

```
// target stripe orientation is aligned with device baseline direction  
bool m_target_aligned;  
  
// force targeted scale calibration and rgb calibration to capture more or less number of target  
images than default  
int m_numImages;  
  
// force target-less calibration to ignore the blocks on the borders of FOV  
bool m_ignore_borders;
```

6.2 Initialize

Initialize method initializes dynamic calibrator. It needs to be called at the very begin of the process.

For target-less calibration, 1280x720 resolution is supported for all devices, and additional native resolution 1280x800 is supported for modules with wide angle lens, for example, D430 and D420 modules.

For targeted calibration, only 1280x720 resolution is supported across all devices.

The function will throw a runtime error if the resolution is different or the calibration parameters are not valid.

```
int Initialize(void *rs400Dev, CalibrationMode mode, int width, int height, bool  
active = false);
```

where

rs400Dev: opaque device handle, currently only librealsense rs2device handle is supported on both Windows and Linux

Dynamic Calibration API Definitions

mode: calibration mode, CAL_MODE_INTEL_TARGETLESS, CAL_MODE_INTEL_TARGETED, CAL_MODE_INTEL_TARGETED_SCALE_ONLY, CAL_MODE_INTEL_RGB_CALIB or CAL_MODE_USER_CUSTOM

width: The width of the images that will be used for dynamic calibration

height: The height of the images that will be used for dynamic calibration

active: true for laser projector is active, false for not active

returns error code:

- DC_SUCCESS - no issue
- DC_ERROR_INVALID_PARAMETER - invalid parameter passed in
- DC_ERROR_RESOLUTION_NOT_SUPPORTED_V2 - if 1280x800 resolution is requested for devices with old version 2 coefficient table, this is not supported
- DC_ERROR_TABLE_NOT_SUPPORTED - calibration coefficient table on device is not supported
- DC_ERROR_TABLE_NOT_VALID_RESOLUTION – calibration table resolution width or height not valid

6.3 InitializeRgbCalibrator

Initialize RGB calibrator. It needs to be called after scale (targeted) calibration is completed, only 1280x720 resolution is supported across all devices. The function will throw a runtime error if the resolution is different or the calibration parameters are not valid.

```
int InitializeRgbCalibrator(void *rs400Dev, int width = 1280, int height = 720)
```

where

rs400Dev: opaque device handle, currently only librealsense handle is supported on both Windows and Linux

width: The width of the images that will be used for dynamic calibration

height: The height of the images that will be used for dynamic calibration

returns DC_SUCCESS if no issue, error code otherwise:

DC_ERROR_INVALID_PARAMETER - invalid parameter passed in
 DC_ERROR_RESOLUTION_NOT_SUPPORTED_V2 - if 1280x800 resolution is requested for devices with old version 2 coefficient table, this is not supported

DC_ERROR_TABLE_NOT_SUPPORTED - calibration coefficient table on device is not supported

DC_ERROR_TABLE_NOT_VALID_RESOLUTION – calibration table resolution width or height not valid

6.4 AddImages

AddImages method adds a pair of left and right images to dynamic calibrator.

Add a pair of images to be used by dynamic calibration. The images must have the width and height as specified during initialization and must be in 8-bit grayscale format.

```
int AddImages(const uint8_t * leftImage, const uint8_t * rightImage, const
uint8_t * depthImage, const uint64_t timeStamp);
```

where

leftImage: Pointer to captured left image buffer in byte format.

rightImage: Pointer to captured right image buffer in byte format.

depthImage: Pointer to captured depth image buffer in byte format.

timestamp: timestamp on the image pair in milliseconds.

Returns

Target-less calibration:

- DC_SUCCESS if image added ok, otherwise returns error code.
- DC_ERROR_RECT_INVALID_IMAGES
- DC_ERROR_RECT_INVALID_GRID_FILL
- DC_ERROR_RECT_TOO_SIMILAR
- DC_ERROR_RECT_TOO_MUCH_FEATURES
- DC_ERROR_RECT_NO_FEATURES
- DC_ERROR_RECT_GRID_FULL
- DC_ERROR_UNKNOWN

Targeted Calibration:

```
DC_SUCCESS
DC_ERROR_RECT_INVALID_IMAGES
DC_ERROR_RECT_TOO_SIMILAR
DC_ERROR_RECT_TARGET_NOT_FOUND_LEFT
DC_ERROR_RECT_TARGET_NOT_FOUND_RIGHT
DC_ERROR_RECT_TARGET_NOT_FOUND_BOTH
DC_ERROR_SCALE_DEPTH_NOT_CONSISTENT
DC_ERROR_TARGET_UNSTABLE
DC_ERROR_TARGET_TOO_CLOSE
```

```

DC_ERROR_TARGET_TOO_FAR
DC_ERROR_SCALE_ALREADY_CAPTURED
DC_ERROR_SCALE_DEPTH_TOO_SPARSE
DC_ERROR_SCALE_DEPTH_NOT_A_PLANE
DC_ERROR_SCALE_TARGET_TILT_ANGLE_BIG
DC_ERROR_SCALE_FAILED_COMPUTE
DC_ERROR_PHASE_COMPLETED
DC_ERROR_UNKNOWN

```

6.5 **GetLastPhoneROILeftCamera**

(for targeted calibration only)

Get last position of target (printed or phone) in left image position is defined by a quadrilateral plane boundary with four corner points

```
int GetLastPhoneROILeftCamera(float ptr[PHONELOC_DIM])
```

where

```

ptr four corner points surrounding the target in the order
  top left corner x and y
  top right corner x and y
  bottom right corner x and y
  bottom left corner x and y

```

return error code indicate target location status

- DC_SUCCESS
- DC_ERROR_NOT_IMPLEMENTED – if called in target-less mode
- DC_ERROR_RECT_TARGET_NOT_FOUND_LEFT

6.6 **GetLastPhoneROIRightCamera**

(for targeted calibration only)

Get last position of target (printed or phone) in right image position is defined by a quadrilateral plane boundary with four corner points

```
int GetLastPhoneROIRightCamera(float ptr[PHONELOC_DIM])
```

where

```
ptr four corner points surrounding the target in the order
```

top left corner x and y
top right corner x and y
bottom right corner x and y
bottom left corner x and y
return error code indicate target location status

- DC_SUCCESS
- DC_ERROR_NOT_IMPLEMENTED – if called in target-less mode
- DC_ERROR_RECT_TARGET_NOT_FOUND_RIGHT

6.7 GetLastTargetDistance

Get target distance - the last distance of the target/phone from camera. The distance is returned in millimeters, but generally can be considered as inaccurate as the updated calibration isn't ready by this time. This function returns value only in the scale phase of the process. The distance of the phone target in mm or -1.0 if the phone wasn't detected yet or not in scale phase of the process.

float **GetLastTargetDistance()**

returns distance of the phone target in mm or -1.0 if the phone wasn't detected yet or not in scale phase of the process.

6.8 AccessGridFill

AccessGridFill method returns an array of grid quantifies how the cells are filled with features. This method only needs to be called once at the beginning and the pointer to GridFill array will be used to check for continuous update.

void **AccessGridFill**(GridFill *& grid, int & gridWidth, int & gridHeight);

grid: Pointer to GridFill array with size of gridWidth * gridHeight in row major.

gridWidth: Grid width as output.

gridHeight: Grid height as output.

6.9 GetLastFrameFeaturesGrid

GetLastFrameFeaturesGrid method returns the current status of feature detection in the grid array of the last frame. The features are updated whenever new images are added. This method only needs to be called once at the beginning and the pointer to GridFeatures array will be used to check for continuous update.

```
void GetLastFrameFeaturesGrid(const GridFeatures *& grid, int & gridWidth, int & gridHeight);
```

grid: Pointer to GridFeatures array with size of gridWidth * gridHeight in row major.

gridWidth: Grid width as output.

gridHeight: Grid height as output.

6.10 GetGridLevels

```
void GetGridLevels(const GridLevel *& grid, int & gridWidth, int & gridHeight);
```

GetGridLevels method return the current status of feature detection in each cell of the grid array. The features are updated whenever new images are added. This method only needs to be called once at the beginning and the pointer to GridLevel array will be used to check for continuous update.

grid: Pointer to GridLevel array with size of gridWidth * gridHeight in row major.

gridWidth: Grid width as output.

gridHeight: Grid height as output.

6.11 GetGridLevelScore

GetGridLevelScore method evaluates the grid level and return a score how well the grid is filled.

float **GetGridLevelScore**();

Return: The score between 0.0f and 1.0f. 0.0f means empty grid. 1.0f means grid level is high for every cell.

6.12 **IsGridFull**

IsGridFull method indicates whether the dynamic calibration is completed.

bool **IsGridFull**()

returns

- False: Dynamic calibrator is still working on calibration.
- True: Dynamic calibration is completed.

6.13 **IsOutOfCalibration**

int **IsOutOfCalibration**(bool & outOfCalibration);

Whether the device is out of calibration. The function will fail to evaluate when `DSDynamicCalibration::CanComputeCalibration` returns false due to insufficient data. You should only use this function when `DSDynamicCalibration::IsGridFull` returns true when following the official process.

outOfCalibration: Returns whether is out of calibration or not

returns error code of the evaluation, `DC_SUCCESS` if successful, `DC_ERROR_PREMATURE` if called before scale calibration is completed in targeted calibration.

6.14 **GetCalibrationError**

(target-less calibration only)

bool **GetCalibrationError**(float & calibrationError);

Get the calibration error RMS (not normalized). This function is not part of the official process and it is not guaranteed that calibration calculated when `DSDynamicCalibration::IsGridFull` returns false will meet the specification.

calibrationError: Returns the calibration error

return: `DC_SUCCESS` if the evaluation was successful for target-less rectification. `DC_ERROR_NOT_APPLICABLE` for targeted calibration.

6.15 **IsRectificationPhaseComplete**

(targeted calibration only)

bool **IsRectificationPhaseComplete**();

Check if rectification phase is completed, return true if completed otherwise false.

6.16 **IsScalePhaseComplete**

(targeted calibration only)

bool **IsScalePhaseComplete**();

Check if scale calibration phase is completed, return true if completed otherwise false.

6.17 **NumOfImagesCollected**

Get number of image pairs collected in the current calibration phase. return number of image pairs (left/right for target-less calibration and left/right/depth for targeted calibration)

```
int NumOfImagesCollected();
```

6.18 SetIntermediateRectificationCalibration

(targeted calibration only)

Apply the intermediate calibration results once the rectification phase is completed.

```
int SetIntermediateRectificationCalibration();
```

where it returns

DC_SUCCESS on success, error code on failure.

DC_ERROR_NOT_APPLICABLE when called in target-less calibration

DC_ERROR_FAIL if there is problem and failed

6.19 GoToScalePhase

(targeted calibration only)

Switch to scale calibration phase. This has to be called after the rectification phase is completed before starting scale calibration phase.

```
bool GoToScalePhase();
```

6.20 GetPhase

Get current calibration phase, return DC_TARGETED_RECTIFICATION_PHASE for rectification phase, DC_TARGETED_SCALE_PHASE for scale phase.

```
DC_PHASE GetPhase();
```

6.21 GetTargetedCalibrationCorrection

(targeted calibration only)

Returns the updated calibration in rotation modification around the x/y/z axes once the scale phase is complete, where

Dynamic Calibration API Definitions

rx Returns rotation modification around the x-axis

ry Returns rotation modification around the y-axis

rz Returns rotation modification around the z-axis

and true on success, false on failure.

bool **GetTargetedCalibrationCorrection**(double& rx, double& ry, double& rz);

This API requires the scale phase is completed.

6.22 GetRGBCalibrationCorrection

(RGB calibration only) Returns the updated calibration in rotation modification around the x/y/z axes once the scale phase is complete. This API requires the scale phase is completed.

bool GetRGBCalibrationCorrection(double& rx, double& ry, double& rz, double& tx, double& ty, double& tz);

where

rx Returns rotation modification around the x-axis

ry Returns rotation modification around the y-axis

rz Returns rotation modification around the z-axis

tx Returns translation modification along the x-axis

ty Returns translation modification along the y-axis

tz Returns translation modification along the z-axis

return true on success, false on failure.

6.23 UpdateCalibrationTables

Get the updated calibration tables and write to device. For target-less, you should only use this function when `DSDynamicCalibration::IsGridFull` returns true. For targeted, only use this function after scale calibration is completed.

int UpdateCalibrationTables();

where

Return

- DC_SUCCESS on success

- DC_ERROR_FAIL on failure

6.24 **GetVersion**

Get version of dynamic calibration as a string

static const char * **GetVersion()**

where

return: Version of Dynamic Calibration API